

KELEN

K50S KELIT Standard-Verlängerung 1/2" u. 3/4"

2661050

Anwendungsbereiche

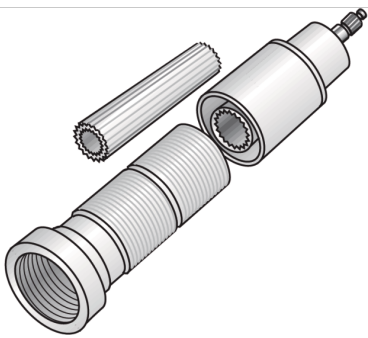

Stufenlose Verlängerung ohne Sichtteile bis 150mm, passend zu KE50 und K50C

Zertifizierungen



KE KELIT GmbH

A 4020 Linz, Ignaz-Mayer-Straße 17, Austria, Europe

TELEFON +43 (0) 50 779 E-MAIL office@kekelit.com

www.kekelit.com

Spezifikationen

Produktinformation	
VPE1	1,00 SA1
VPE2	20,00 KT1
VPE3	80,00 KT2
VPE4	1920,00 PAL
Gewicht	0,168 KGM
Text	KELIT Standard-Verlängerung
INTRNR	84819000
Hauptwarengruppe	KELEN
Warengruppe	KELEN Zubehör
Code	K50S

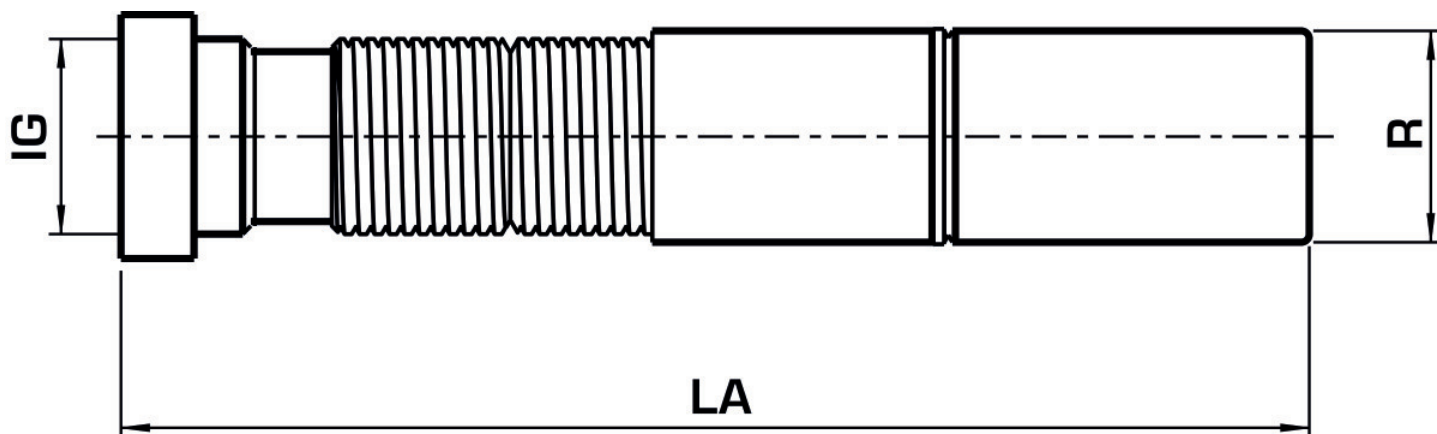

Art. Nr	Bezeichnung	d1 mm	L1 mm
2661050	1/2" u. 3/4"	26	150